

aBP-Module®

Continuous product feeding without bridging

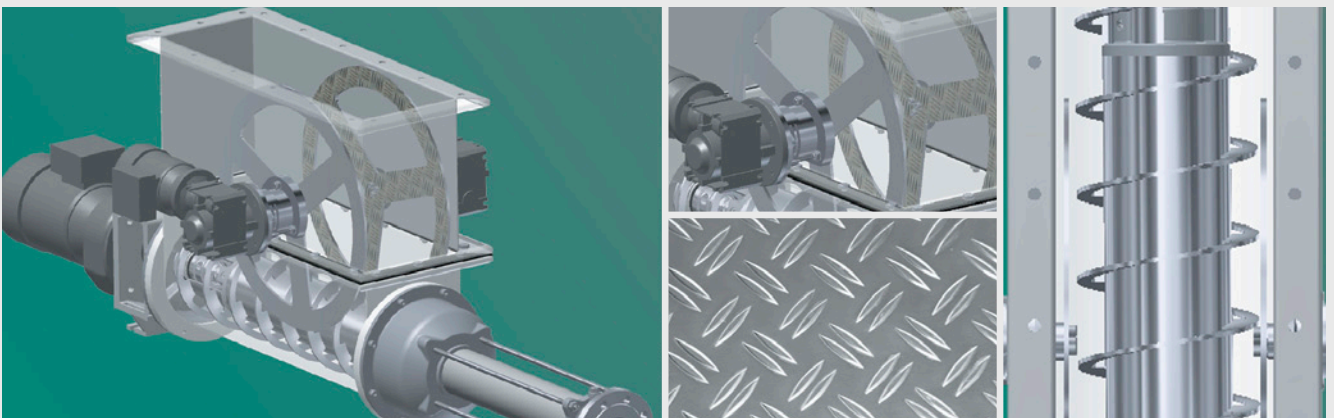

The efficient system against bridging

Function and Construction

With its aBP-Module® NETZSCH provides the solution to bridging. This system, available for the revised pump series BF / SF ensures continuous conveyance of your medium, no matter how.

aBP stands for

a
synchronous
B
ridge
P
reventing

Function

The aBP-Module® consists of a top hopper with two inner spoked wheels. The spoked wheels are located close to the hopper walls, creating the effect of "moving hopper walls" which impart a shearing effect in the medium. The speed difference of the spoked wheels, which is independently adjustable, creates the required shearing effect, thereby reliably preventing bridge building inside the hopper. The structured surface of the spoked wheels further supports product agitation.

Advantages

- No bridge building
- High operational safety
- Ideal adjustment of the differing speed of spoked wheels to the characteristics of the conveyed media
- Optimal filling of screw conveyor
- Reliable product feeding towards screw conveyor
- Safe measuring and controlling of filling due to free shaft centre
- Compatibility with all NEMO® pumps of series BF / SF
- Retrofittable without modification of pump
- Sturdy construction
- Maintenance friendly



Example of a NETZSCH aBP-Module®

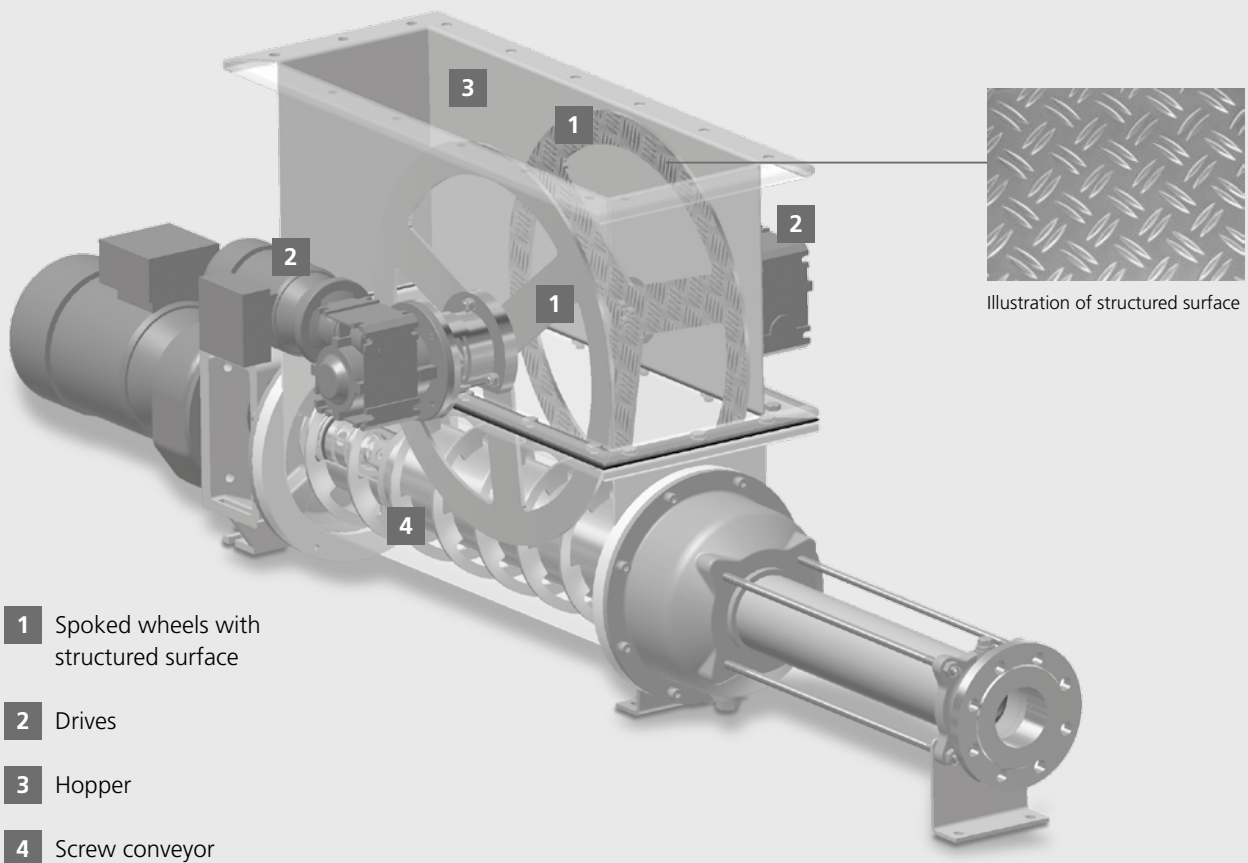

- 1** Spoked wheels with structured surface
- 2** Drives
- 3** Hopper
- 4** Screw conveyor

Further characteristics

Material	Stainless steel 1.4301
Shaft Sealing	Packed stuffing box
Drives	<ul style="list-style-type: none"> ■ Two independent drives with screw gears, speed control by a frequency inverter ■ Independent from pump speed ■ Optional drive direction
Series	<ul style="list-style-type: none"> ■ Series BF / SF ■ Sizes NM045 to NM090 ■ Optional hopper length

The NETZSCH Group is an owner-managed, internationally operating technology company headquartered in Germany.

The three Business Units – Analyzing & Testing, Grinding & Dispersing and Pumps & Systems – provide tailored solutions for highest-level needs. Over 2,200 employees at 125 sales and production centers in 23 countries across the globe guarantee that expert service is never far from our customers.

The NETZSCH Business Unit Pumps & Systems offers NEMO® progressing cavity pumps, TORNADO® rotary lobe pumps, screw pumps, macerators/grinders, dosing systems and equipment custom built and challenging solutions for different applications on a global base.

NETZSCH Mohnopumpen GmbH
Geretsrieder Straße 1
84478 Waldkraiburg
Germany
Tel.: +49 8638 63-0
Fax: +49 8638 67981
info.nmp@netzsch.com

www.netzsch.com